

4. Optics review

4.1 Ray Optics

Light travels in different optical media in accordance with a set of geometrical rules

4.2 Classical (Wave) Description

Light is an EM wave

4.3 Quantum (Particle) Description

Localized, massless quanta of energy – photons

4.4 **Wave / Particle Duality**

Appropriate description depends on experimental device examining light

4.4 Wave / Particle Duality

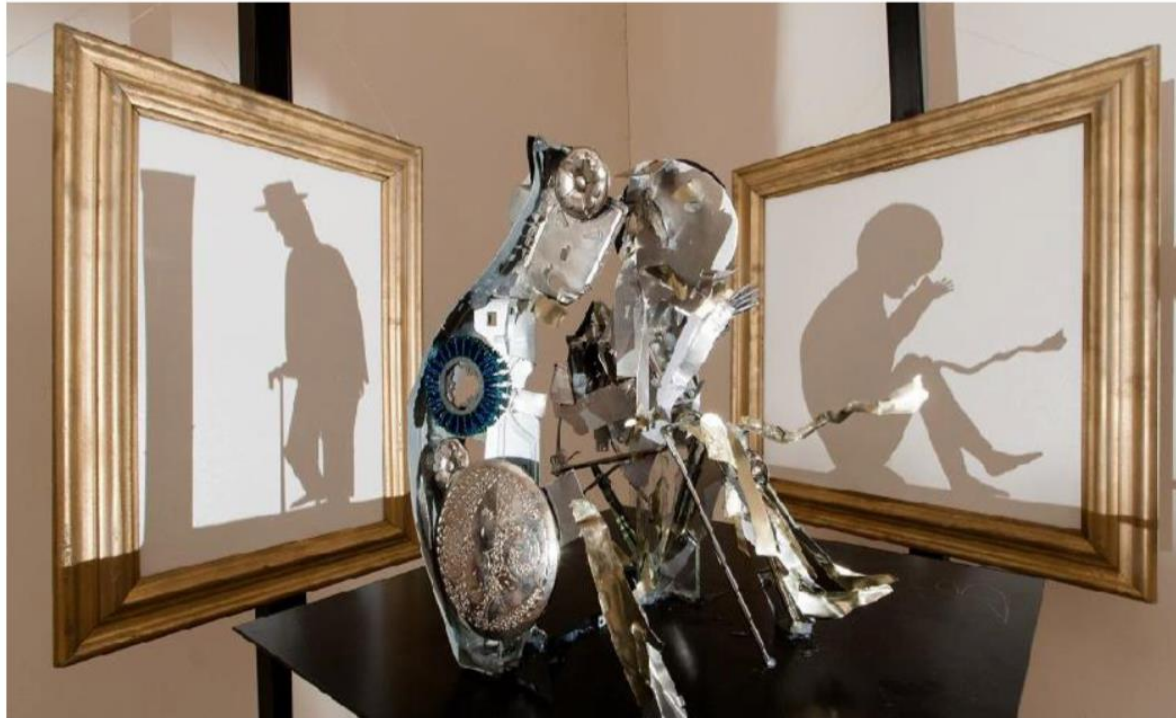

Triantafillos Vaitzis, Greek artist born in 1976, «The beginning of the end and the end of the beginning».

Wave / Particle Duality - Light

Particles:

- 1665 Newton: Corpuscular theory
- 1888 Hallstadt: Photoelectric effect
- 1905 Einstein: Interpretation

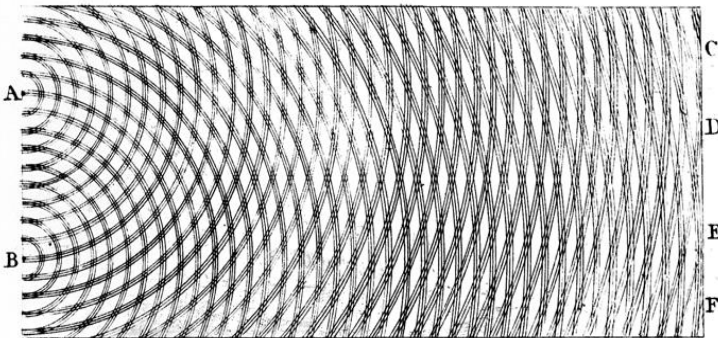

Waves:

- 1690 Huygens: Wave theory
- 1802 Young: Double slit experiment
- 1861 Maxwell: Electromagnetic waves

Wave / Particle Duality - Light

Photons versus EM waves

- Stand outside in the sun. The shadow your body makes in sunlight suggests that light travels in straight lines from the sun and is blocked by your body. In this, light behaves like a collection of particles fired from the sun.

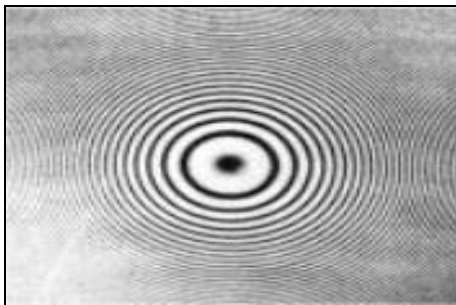

- Place two sheets of glass together with a little water between them. With care, you will see fringes. These are formed by the interference of waves.

Wave/Particle Duality - Light

Photons versus EM waves

Apart its wave-like properties, that are demonstrated by:

- Refraction
- Interference and
- Polarization

Light also shows particle-like behavior

- Photoelectric effect
- « Low intensity » emission and absorption
(Shot noise)

Wave/Particle Duality - Light

Photons versus EM waves

- Light is composed of small **parcels**^(*) called photons.
- Photons are now thought to be carriers of EM force.
- The photon concept and the wave theory of light complement each other
- Wave-like or particle behavior depends on the specific phenomenon being observed
- This duality in the nature of photons is a key aspect of Quantum theory.

() They are called parcels (or packets) rather than particles or waves because, depending on their interactions with other matter, they have either particle or wavelike behavior.*

Wave / Particle Duality

High frequency (X- or γ -rays)

Momentum and energy of photon increase

Photon (particle) description dominates

Low Frequency (radio waves)

Interference/diffraction easily observable

Wave description dominates

What about matter ?

Our understanding of the structure of matter was led by a series of breakthrough in early 20th century.

Matter

Particle behavior

Kinetic energy $E_{\text{kin}} = \frac{1}{2}mv^2$

Momentum $p = mv$

Translational energy described
by the classical Newtonian mechanics

Wave-like behavior

Wavelength $\lambda = \frac{h}{mv}$
(de Broglie wave)

$h =$ Planck constant

Quantized energy obtained
by solution of the Schrödinger equation

Atomic Spectra

Atomic spectrum of hydrogen

- Electrical discharge is passed through a glass tube with hydrogen
- ➔ Tube will emit light whose wavelengths can be measured with a spectrometer
- The line spectrum (intensity vs. wavelength) is characteristic of the particular element

The electron's energy is quantized !!

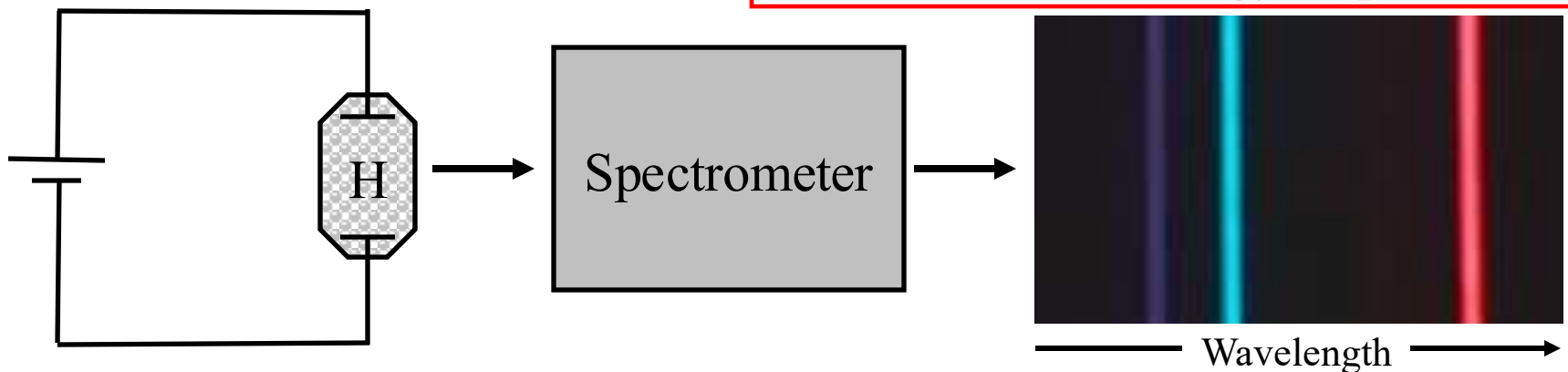

Atomic Spectra

Atomic spectrum of hydrogen

Wavelength (nm)	Relative Intensity	Transition	Color
383.5384	5	9 \rightarrow 2	Violet
388.9049	6	8 \rightarrow 2	Violet
397.0072	8	7 \rightarrow 2	Violet
410.174	15	6 \rightarrow 2	Violet
434.047	30	5 \rightarrow 2	Violet
486.133	80	4 \rightarrow 2	Bluegreen (cyan)
656.272	120	3 \rightarrow 2	Red
656.2852	180	3 \rightarrow 2	Red

Atomic Spectra

Significance

- The line spectrum of hydrogen suggests that only certain energies are allowed for the electron in the atom
(in contrast, if any energy level were allowed, the emission spectrum would be continuous)
- This suggests that the energy levels occupied by electrons are quantized

Wave Nature of Electron

Theory of light 1920's:

"Classical" wave theory (since 1690):
light is a wave phenomenon

Photoelectric effect:
light has particle properties

Einstein: Relativity



Louis de Broglie

Born: 15 Aug 1892 in Dieppe, France
Died: 19 March 1987 in Paris, France

Louis de Broglie (1924):

**Might electrons and other "particles"
exhibit wave-like properties?**

Wave Nature of Electron

The de Broglie Hypothesis (1924):

Relativity

$$E = mc^2 = \sqrt{\underbrace{p^2 c^2}_{\text{Kinetic energy term}} + \underbrace{m_0^2 c^4}_{\text{Rest mass energy term}}}$$

rest mass
 $m_{0,ph}=0$

Momentum
of a photon

$$p = \frac{E}{c}$$

**The de Broglie
Hypothesis**

$$\lambda = \frac{h}{p}$$

for photon

$$\lambda = \frac{h}{p} \stackrel{?}{=} \frac{h}{mv}$$

for an electron?

Photoelectric effect

$$E = h\nu = \frac{hc}{\lambda}$$

$$\frac{h}{\lambda} = \frac{E}{c}$$

Wavelength energy
relation

Wave Nature of Electron

Confirmation of de Broglie's Hypothesis:

- 1927 Clinton Davisson and Lester Germer:
Davisson-Germer experiment

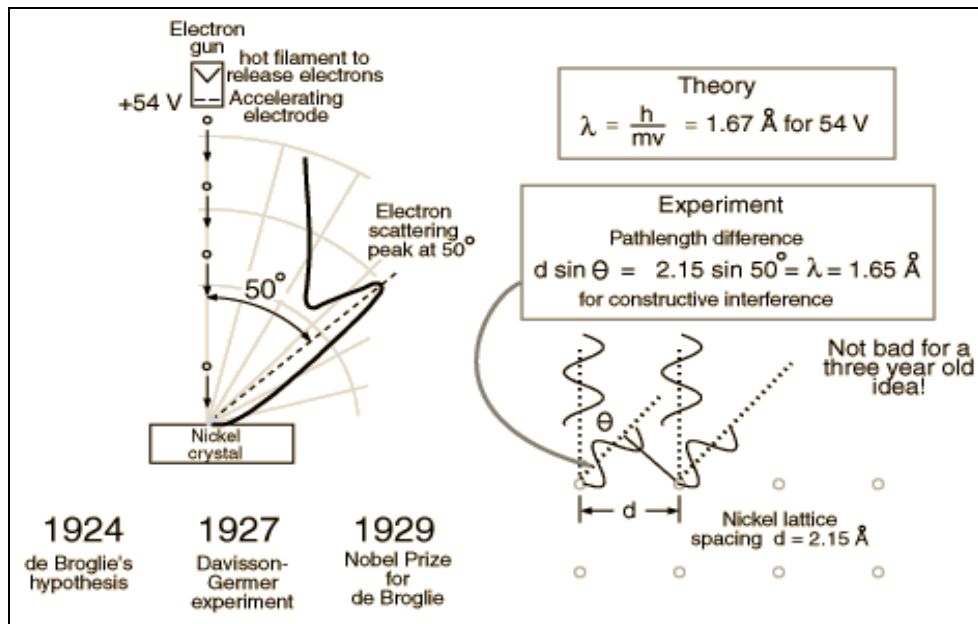

- Slow electrons impact on a crystalline Nickel target
- ➔ Angular distribution of reflected electron intensity = angular distribution predicted for X-rays (waves) by Bragg(*).

(*) *Friedrich and Knipping experimentally showed the interference of X-rays (1912); the results were interpreted by Bragg*

Wave and Particle Concepts

De Broglie's equations for particles

Momentum $p = mv = \frac{h}{\lambda}$

de Broglie Wavelength $\lambda = \frac{h}{p}$

Frequency
(obeys Einstein relation) $\nu = \frac{E}{h}$

**Each equation
contains**

- **particle concepts (p and E)**
- **AND**
- **wave concepts (λ and ν).**

Wave and Particle Concepts

Significance of de Broglie's equations

- The momentum of a photon can be specified by its wavelength
- Like photons, all forms of matter (i.e. electrons) have wave and particle properties
- This idea played an important role in the development of quantum mechanics.

Wave Mechanics

The wave function and the wave equation

- **De Broglie waves** are represented by a simple quantity called a **wave function Ψ**
- in quantum mechanics a particle is completely described by the **wave function**, which is a complex function of time and position **$\Psi = \Psi(\mathbf{x}, t)$**
- The **wave function** can be determined by solving the **Schrödinger** wave equation

Schrödinger Equation

"The Schrödinger equation plays the role of Newton's laws and conservation of energy in classical mechanics - i.e., it predicts the future behavior of a dynamic system."

Schrödinger's approach:

- the wave-particle duality had been shown for both photons and electrons (particles)
- ➔ mathematics describing the wave-like behavior might be similar to that for describing classical waves



Erwin Schrödinger

Born: 12 Aug 1887 in Erdberg,
Vienna, Austria

Died: 4 Jan 1961
in Vienna, Austria

Schrödinger's wave equation

Significance of terms

Potential energy

$$\frac{-h^2}{8\pi^2 m} \frac{d^2\psi}{dx^2} + (V - E)\psi = 0$$

Allowed System Energy
(potential and kinetic energy)

- $\psi^2(x)dx$ describes the probability of finding the particle in the length segment between x and $x + dx$.

Particle in a Box

Experiment consisting of a single particle bouncing around inside a box with the following conditions

- single point particle
- no forces
(zero potential energy $V(x)$)
- at the walls of the box:
potential rises to infinity
(impenetrable wall)

Let's solve:

$$\frac{-\hbar^2}{8\pi^2 m} \frac{d^2 \psi}{dx^2} + (V - E)\psi = 0$$

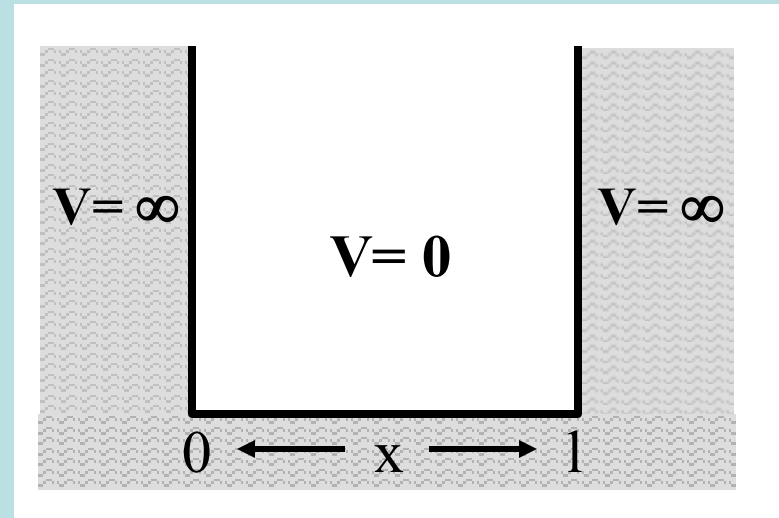

Characteristics of the potential $V(x)$

Particle in a Box

For a particle confined to moving along the x-axis :

$$\frac{\hbar^2}{2m} \frac{\partial^2 \Psi}{\partial x^2} + (E - V) \Psi = 0$$



$$-\frac{\hbar^2}{2m} \frac{\partial^2 \psi}{\partial x^2} = E \psi$$

Boundary condition:

$$\begin{aligned} V(x) &= 0 \\ \psi(x) &= 0 \quad \text{at } x = 0 \text{ and } x = l \end{aligned}$$

The quantized energy levels can be determined by solving the equation:

$$E_n = \frac{n^2 \hbar^2}{8ml^2} \quad \psi_n(x) = \left(\frac{2}{l}\right)^{1/2} \sin\left(\frac{n\pi x}{l}\right)$$

Eigen values: E_n

Eigen functions: Ψ_n

n = positive integer

Particle in a box

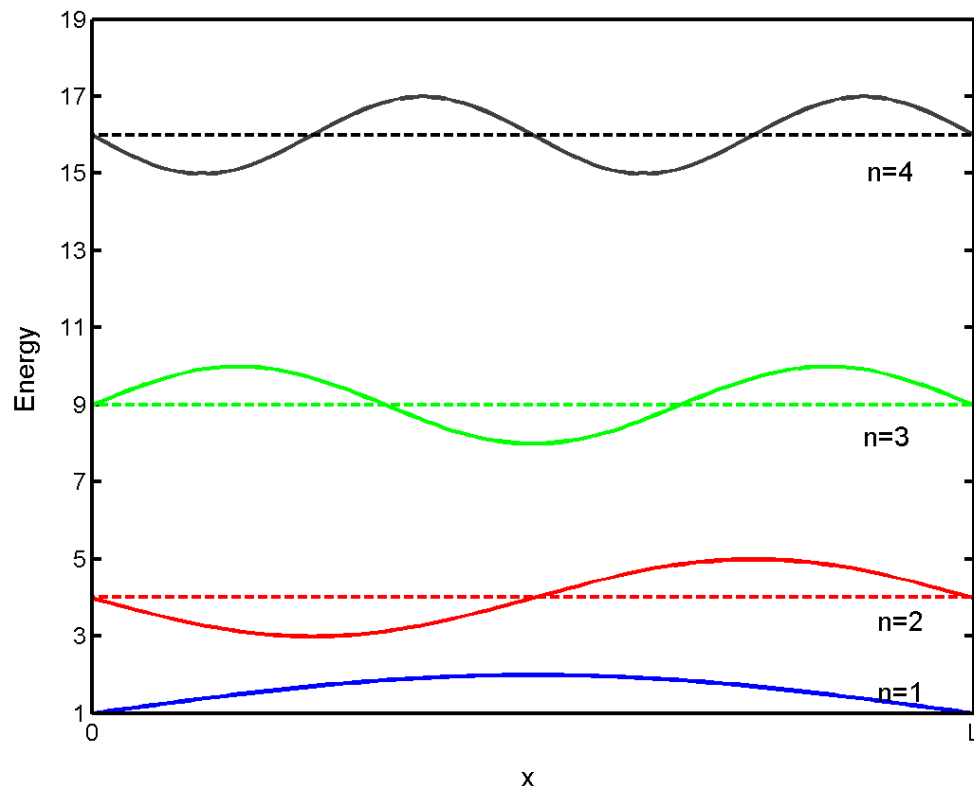

- In general the n^{th} wavefunction has $(n-1)$ nodes.
- Energy levels

$$E_n = \frac{n^2 h^2}{8ml^2}$$

(node = place where the wavefunction is zero)

Particle in a Box

The gap between two successive levels E_n and E_{n+1} can be given as

$$E_n = \frac{n^2 h^2}{8ml^2}$$



$$\Delta E = (2n + 1) \frac{h^2}{8ml^2}$$



This equation reveals that the gap between two successive levels decreases as l^2 when the length of the box increases. Translational energies of atoms and molecules, which involve displacement over a large distance compared to the atomic scale, will have very small spacing and can be considered not to be quantized—that is, treatable by classical mechanics. This model also explains that when a bond is formed between two atoms, the length in which the bonding electrons are confined increases (spreads over two atoms). Consequently, the energy E_n is lowered, stabilizing the formation of the bond, because a lower energy configuration is always preferred.

Wave Mechanics

Significance

- The Schrödinger wave equation lies at the heart of quantum mechanics
- In principle, the wave equation can be solved to provide the wave functions and allowed discrete energy levels of quantum mechanical system such as atoms and molecules.
- The quantity $\psi^2(x)dx$ describes the probability of finding the particle in the length segment between x and $x + dx$.
- For a specific energy level that the electron occupies, its corresponding wave function defines an orbital that can be visualized as the region of space where the probability of finding an electron is high.

Wave Nature of Matter

In 1999, researchers of the Vienna University diffracted fullerene (C_{60}).

De Broglie wavelength: 2,5 pm.

Molecule diameter: 1 nm.

This is the largest object showing a wave behaviour in 1999.

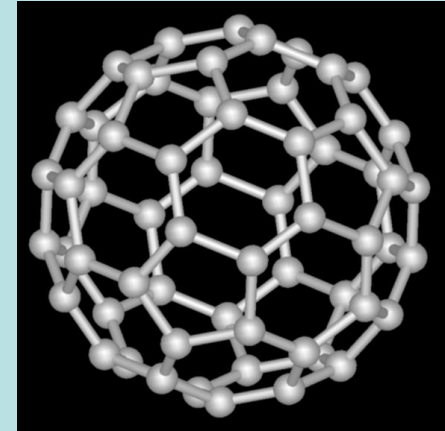

*M. Arndt, O. Nairz, J. Voss-Andreae, C. Keller, G. van der Zouw et A. Zeilinger
« Wave-particle duality of C60 », Nature, vol. 401, 1999, p. 680-682.*